

MAKE: FORD

TYPE: Courier / Ranger

MODEL: U.F.S.

YEAR: 1987 on

DETAIL: Pickup / Dual Cab,
Mazda Proceed, Ranger 2000 FORD-51



FRONT	TYPE	QTY	PART NUMBER
<p>TORSION BAR</p> <p>Type 'D'</p> <p>Heavy Duty Rate Increased Length 926mm</p>	D	2	TB39-1546 (Pair)
<p>SHOCK ABSORBER</p> <p>Type 'A' 'B' 'C'</p> <p>Heavy Duty Gas</p>	B	2	GS19-082P

REAR	TYPE	QTY	PART NUMBER
<p>LEAF SPRING</p> <p>Type 'B'</p> <p>5 + 2 Leaves Raised Height (35mm Lift) Medium Load to GVM</p> <p>B 2 MAZ-003-R</p> <p>6 + 2 Leaves Heavy Duty Raised Height (35mm Lift) 200Kg to GVM</p> <p>B 2 B2600-4X4-R</p>			
<p>SHACKLE BUSH KIT</p> <p>Rubber Polyurethane Metal</p> <p>'A' 'B' 'C'</p> <p>Kit Contains: 2 x SPF311 4 x SPF502 4 x SPF753</p> <p>B 1 PB39-1058K</p>			
<p>U-BOLT KIT</p> <p>Type 'A' 'B' 'C'</p> <p>Kit Contains: 2 x UB59-453-3</p> <p>A 2 UB59-453-3K</p>			
<p>SHOCK ABSORBER</p> <p>Type 'A' 'B' 'C'</p> <p>Heavy Duty Gas</p> <p>A 2 GS19-081T</p>			
<p>SHACKLE KIT</p> <p>'A' 'B' 'C' 'D'</p> <p>Greasable: Fit in Pairs</p> <p>C 2 SK59-010</p>			

MAKE: FORD **TYPE:** Maverick
MODEL: Y60 **YEAR:** 1988 on
DETAIL: Station Wagon, S.W.B. & L.W.B.
 Australia **FORD-53**



FRONT		TYPE	QTY	PART NUMBER
COIL SPRING Type 'C' 				
S.W.B. Linear Rate Raised Height (50mm Lift)			2	C45-094 (Pair)
L.W.B. Linear Rate Raised Height (50mm Lift)			2	C45-102 (Pair)
SHOCK ABSORBER Heavy Duty Gas Type 'A' 'B' 'D'		D	2	GS45-114
STEERING DAMPER Type 'A'				
Pre 09/1989 Heavy Duty (Big Body) Complete with Fittings		A	1	SD45-834
09/1989 on Heavy Duty (Big Body) Complete with Fittings		A	1	SD45-836
UNDER BODY BUSH KIT Polyurethane Bush				
NOTE: See Rear Under Body Bush Kit				
CASTOR KIT Front Radius Arm Castor Kit (±2°) 4 x Polyurethane Bushes 4 x Eccentric Bushes (+1 Grease Tube)			- 1	SPF1721K
Raising vehicle will affect castor angle. A wheel alignment is recommended to determine if a castor kit is required.				
GEARBOX SPACER KIT Drive Line Vibration May Occur with Raised Suspension. To Reduce Vibration, Use			- 1	TC45-001K

REAR		TYPE	QTY	PART NUMBER
COIL SPRING Type 'C' 				
S.W.B. Linear Rate Raised Height (50mm Lift)			2	C45-095 (Pair)
L.W.B. Linear Rate Raised Height (50mm Lift)			2	C45-103 (Pair)
SHOCK ABSORBER Type 'A' 'B' 'C'				
Heavy Duty Gas		A	2	GS45-115
UNDER BODY BUSH KIT Polyurethane Bush				
NOTE: Kit Includes Front & Rear Under Body Bushes				
Pre 09/1989 4 x Front Radius Arm (Chassis) Bush 4 x Front Radius Arm (Diff) Bush 2 x Front Panhard Rod Bush 2 x Rear Panhard Rod Bush 8 x Rear Trailing Arm Bush			- 1	PB45-1231K
09/1989 on 4 x Front Radius Arm (Chassis) Bush 4 x Front Radius Arm (Diff) Bush 4 x Front & Rear Panhard Rod Bush 8 x Rear Upper & Lower Trailing Arm Bush			- 1	PB45-1239K

MAKE: FORD

TYPE: Maverick

MODEL: Y60

YEAR: 1988 on

DETAIL: Pickup

Leaf Spring Suspension

FORD-54



FRONT		TYPE	QTY	PART NUMBER
<p>LEAF SPRING Type 'A'</p> <p>7 Leaves – Raised Height (45mm Lift) No Accessories</p> <p>8 Leaves – Raised Height (45mm Lift) 50-100Kg Accessories Heavy Duty Recommended</p>		A	2	Y60-7L-F
<p>8 Leaves – Raised Height (45mm Lift) 50-100Kg Accessories Heavy Duty Recommended</p>		A	2	Y60-8L-F
<p>SHACKLE BUSH KIT</p> <p>Rubber Polyurethane Metal</p> <p>Kit Contains: 8 x SPF2260 4 x SPF2270</p>		B	1	PB45-1018K
<p>U-BOLT KIT</p> <p>Kit Contains: 2 x UB45-669</p>		C	2	UB45-669K
<p>SHOCK ABSORBER</p> <p>Heavy Duty Gas</p>		B	2	GS45-639B
<p>STEERING DAMPER</p> <p>Type 'A'</p> <p>Pre 09/1989 Heavy Duty (Big Body) Complete with Fittings</p> <p>09/1989 on Heavy Duty (Big Body) Complete with Fittings</p>		A	1	SD45-834
<p>SHACKLE KIT</p> <p>Greasable: Fit in Pairs Can be substituted by: Right Hand Side (Anti-Reverse) Left Hand Side (Anti-Reverse)</p>		A	2	SK45-031
<p>Right Hand Side (Anti-Reverse)</p>		D	1	SK59-047
<p>Left Hand Side (Anti-Reverse)</p>		D	1	SK59-048
<p>PIN KIT</p> <p>Greasable: Fit in Pairs</p>		C	2	SP45-026

REAR		TYPE	QTY	PART NUMBER
<p>LEAF SPRING Type 'B'</p> <p>5 + 2 Leaves – Raised Height (50mm Lift) Light Load to GVM</p> <p>6 + 2 Leaves - Raised Height (50mm Lift) 300Kg to GVM Heavy Duty Recommended</p>		B	1	Y60-5+2-R RH
<p>Light Load to GVM</p>		B	1	Y60-5+2-R LH
<p>300Kg to GVM Heavy Duty Recommended</p>		B	1	Y60-6+2-R RH
<p>Heavy Duty Recommended</p>		B	1	Y60-6+2-R LH
<p>SHACKLE BUSH KIT</p> <p>Rubber Polyurethane Metal</p> <p>Kit Contains: 12 x SPF2260</p>		B	1	PB59-1019K
<p>U-BOLT KIT</p> <p>Kit Contains: 2 x UB45-670-1</p>		A	2	UB45-670-1K
<p>SHOCK ABSORBER</p> <p>Heavy Duty Gas</p>		C	2	GS45-081P
<p>SHACKLE KIT</p> <p>Greasable: Fit in Pairs Can be substitute by: Right Hand Side (Anti-Reverse) Left Hand Side (Anti-Reverse)</p>		A	2	SK45-031
<p>Right Hand Side (Anti-Reverse)</p>		D	1	SK59-047
<p>Left Hand Side (Anti-Reverse)</p>		D	1	SK59-048
<p>PIN KIT</p> <p>Greasable: Fit in Pairs</p>		C	2	SP45-026

MAKE: FORD

TYPE: Explorer



MODEL: U.P.





YEAR: 1996 – 04/1999

DETAIL: Station Wagon

FORD-56



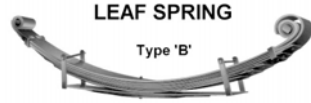



 FRONT 	TYPE	QTY	PART NUMBER
Intentionally Left Blank			





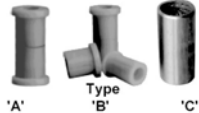

 REAR 	TYPE	QTY	PART NUMBER
 LEAF SPRING Type 'B'			
3 + 1 Leaves Raised Height (40mm Lift) Light Load to GVM	B	2	L19-059
 SHACKLE BUSHES Rubber Polyurethane Metal 'A' Type 'B' 'C'			
Front of Rear Spring Bush Rear of Rear Spring Bush	B B	2 2	SPF1207 SPF469
 U-BOLT KIT Type 'A' 'B' 'C'			
Kit Contains: 2 x UB19-918	A	2	UB19-918K

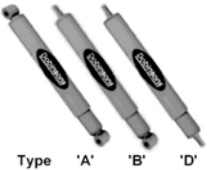
MAKE: FORD **TYPE:** "F" Series
MODEL: F250 4x4 **YEAR:** 2001 on
DETAIL: 4.2L 6 Cyl Turbo Diesel
 7.3L Diesel



FORD-57

 FRONT 	TYPE	QTY	PART NUMBER
 LEAF SPRING Type 'A' 7.3L Turbo Diesel Raised Height (45mm Lift) 6 Leaf Multi Leaf Spring Replaces 2 Leaf Parabolic A 2 FOR-010-F			
4.2L Turbo Diesel Raised Height (45mm Lift) 5 Leaf Multi Leaf Spring Replaces 2 Leaf Parabolic A 2 FOR-011-F <i>When fitting the above springs, U-bolt part number _____ Are required.</i>			
SHACKLE BUSH KIT Rubber Polyurethane Metal  Type 'A' 'B' 'C' Front of Front 2 LS5485 Rear of Front 2 LS5486			
U-BOLT KIT  Type 'A' 'B' 'C' Kit Contains: 2 x UB19-921 C 2 UB19-921K			
SHOCK ABSORBER  Type 'A' 'B' 'D' Heavy Duty Gas A 2 GS59-650A			

 REAR 	TYPE	QTY	PART NUMBER
 LEAF SPRING Type 'B' Raised Height (50mm Lift) 4+2 Leaves B 2 FOR-014-R <i>Longer U-bolts are required When fitting the above spring</i>			
SHACKLE BUSH KIT Rubber Polyurethane Metal  Type 'A' 'B' 'C' Front of Rear 2 LS5486 Rear of Rear 2 LS5485			
U-BOLT KIT  Type 'A' 'B' 'C' Kit Contains: 2 x UB19-222 2 UB19-922K			
SHOCK ABSORBER  Type 'A' 'B' 'D' Heavy Duty Gas A 4 GS45-915A			
AIR BAG KIT Bellows Type 1 RR45800			