





MAKE: MAZDA / FORD **TYPE:** Tribute / Escape



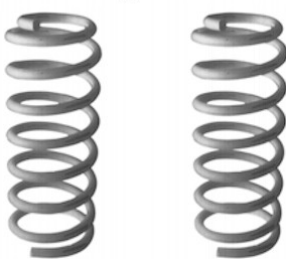

MODEL: YUO B 4Cyl 2L Petrol **YEAR:** 2001 on
YOU 1 V6 3L Petrol

DETAIL: 5 Door

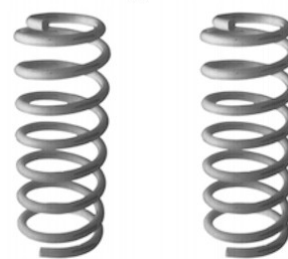

MAZ-52

 FRONT 		TYPE	QTY	PART NUMBER
<p>COIL SPRING Type 'C'</p> 				
<p>Suits: V6 3.0L</p> <p>Linear Rate Standard Height</p>			2	C19-222 (Pair)
<p>Linear Rate Raised Height (45mm Lift) Up to 50Kg Accessories</p>			2	C19-224 (Pair)
<p>SHOCK ABSORBER</p>  <p>Type 'A' 'B' 'C'</p>				
<p>Heavy Duty Gas</p>			2	Under Development

 REAR 		TYPE	QTY	PART NUMBER
<p>COIL SPRING Type 'C'</p> 				
<p>Linear Rate Standard Height</p>			2	C19-223 (Pair)
<p>Linear Rate Raised Height (50mm Lift) Light Load to GVM</p>			2	C19-225 (Pair)
<p>SHOCK ABSORBER</p>  <p>Type 'A' 'B' 'C'</p>				
<p>Heavy Duty Gas</p>			2	Under Development